

MP10

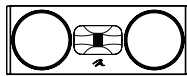

C10

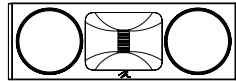

C100



## WARNING!

- Refer servicing to a qualified technician.
- To prevent fire or shock hazard, do not expose this module to moisture.
- Turn amplifier off should any abnormal conditions occur.
- Do not drive speaker beyond its rated power.



The lightning bolt flash with arrowhead symbol, within an equilateral triangle, is intended to alert the user to the presence of potentially "dangerous voltage" within the product's enclosure that may be sufficient to constitute a risk of electric shock.



The exclamation point within an equilateral triangle is intended to alert the user to the presence of important operating and maintenance (servicing) instructions in the literature accompanying the appliance.



In accordance with the European Union WEEE (Waste Electrical and Electronic Equipment) directive effective August 13, 2005, we would like to notify you that this product may contain regulated materials which upon disposal, according to the WEEE directive, require special reuse and recycling processing. For this reason Martin Logan has arranged with our distributors in European Union member nations to collect and recycle this product at no cost to you.

To find your local distributor please contact the dealer from whom you purchased this product, email [info@martinlogan.com](mailto:info@martinlogan.com) or visit the distributor locator at [www.martinlogan.com](http://www.martinlogan.com).

Please note, only this product itself falls under the WEEE directive. When disposing of packaging and other related shipping materials we encourage you to recycle these items through the normal channels.



*\*Motion STAND25 sold separately.*

<b>Connection</b> .....	<b>6</b>
Single Wire Connection (C10/B10/MP10) .....	6
Single Wire Connection (F200/F100/C100/B100/F20/F10) . . .	6
Jumper Clips (F200/F100/C100/B100/F20/F10) . . .	6
Bi-Wire Connection (F200/F100/C100/B100/F20/F10) . . .	6
Passive Bi-Amplification (F200/F100/C100/B100/F20/F10) . . .	7
Active Bi-Amplification. . . . .	7
<b>Placement</b>	
(F200/F100/B100/F20/F10/B10) .....	<b>8</b>
<b>Frequently Asked Questions</b> .....	<b>9</b>
<b>Troubleshooting</b> .....	<b>10</b>
<b>Contacting Customer Service</b> .....	<b>10</b>
<b>General Information</b> .....	<b>11</b>
Warranty Information .....	11
Serial Number. . . . .	11
Service . . . . .	11
<b>Specifications</b> .....	<b>12</b>
<b>Dimensional Drawings</b> .....	<b>18</b>

Serial Number: \_\_\_\_\_

Record your serial number here for easy reference. You will need this information when filling out your warranty registration. The serial number is located near the binding posts and on the product carton.

**Motion XT F200/F100**  
**Motion F20/F10**

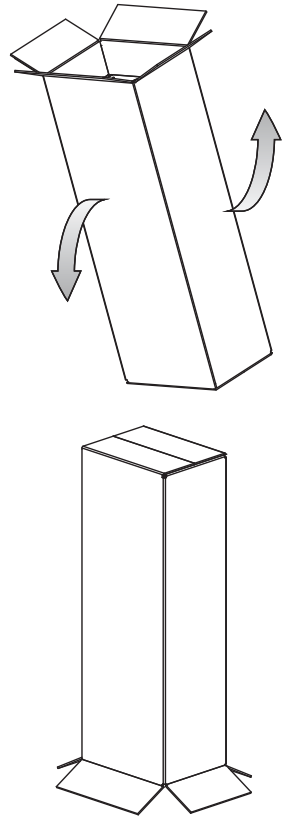
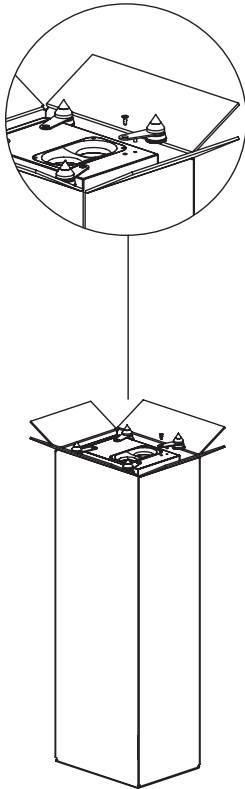
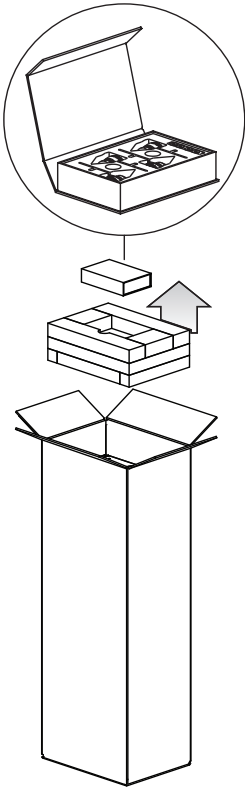

**Motion XT B100**  
**Motion B10**

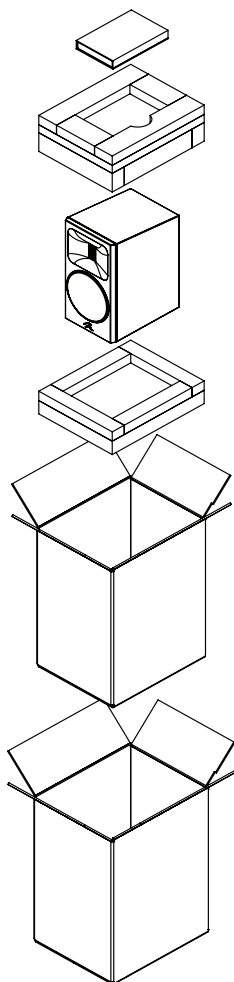

**Motion XT C100**  
**Motion C10**

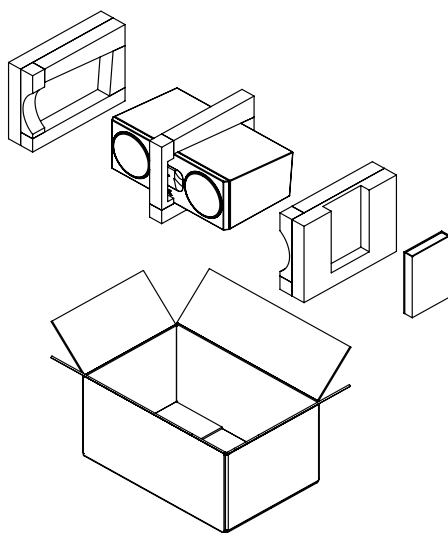

**Motion MP10**

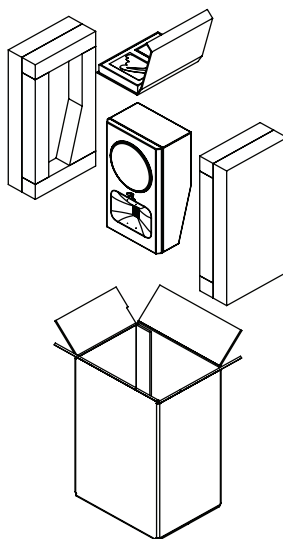

## CONNECTION

**WARNING!** Turn your amplifier off before making or breaking any signal connections!



### SINGLE WIRE CONNECTION (C10/B10/MP10)

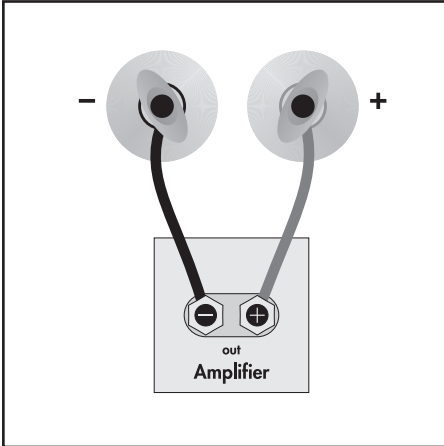

### SINGLE WIRE CONNECTION (F200/F100/C100/B100/F20/F10)

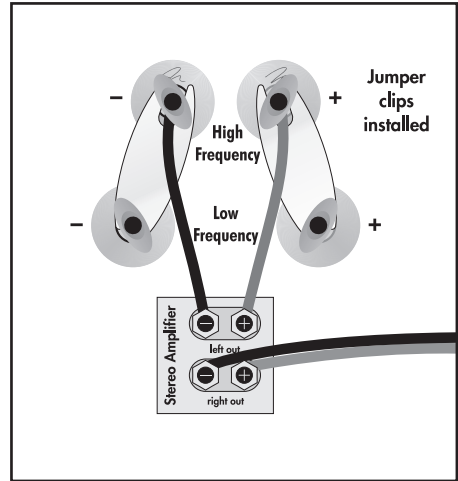

### BI-WIRE CONNECTION (F200/F100/C100/B100/F20/F10)

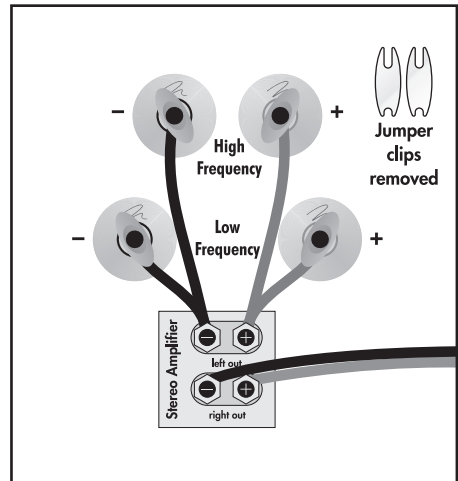

### JUMPER CLIPS (F200/F100/C100/B100/F20/F10)

**WARNING!** Only after jumper clips are removed may you connect individual runs of speaker cable from your amplifiers to the high-frequency and low-frequency signal input binding posts. Damage will occur to your amplifiers if the jumper clips are not removed.



In some countries federal law prohibits MartinLogan from supplying jumper clips. If none are found installed under your speakers binding posts, please refer to 'Bi-Wire Connection' for connection instructions.

**PASSIVE BI-AMPLIFICATION  
(F200/F100/C100/B100/F20/F10)**

**Horizontal Passive Bi-Amplification**

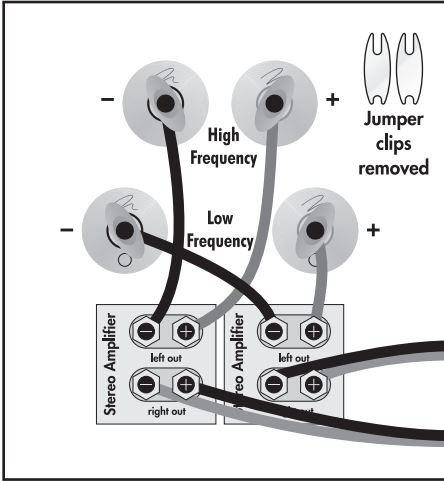

**Vertical Passive Bi-Amplification**

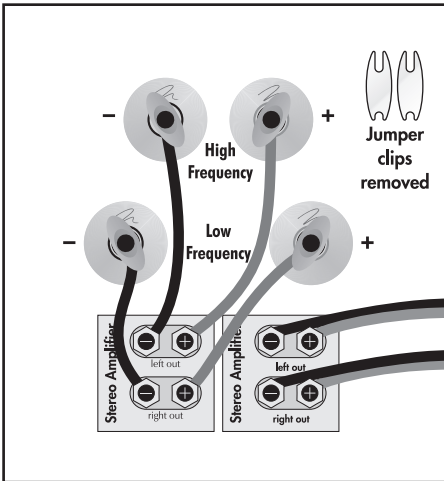

**ACTIVE BI-AMPLIFICATION**

We do not recommend active bi-amplification. The internal crossover can not be bypassed. This connection method seriously degrades performance.

# PLACEMENT

## BREAK IN



**72 hrs**

Allow approximately 72 hours of break-in at 90 dB (moderate listening levels) before any critical listening.

## PLACEMENT

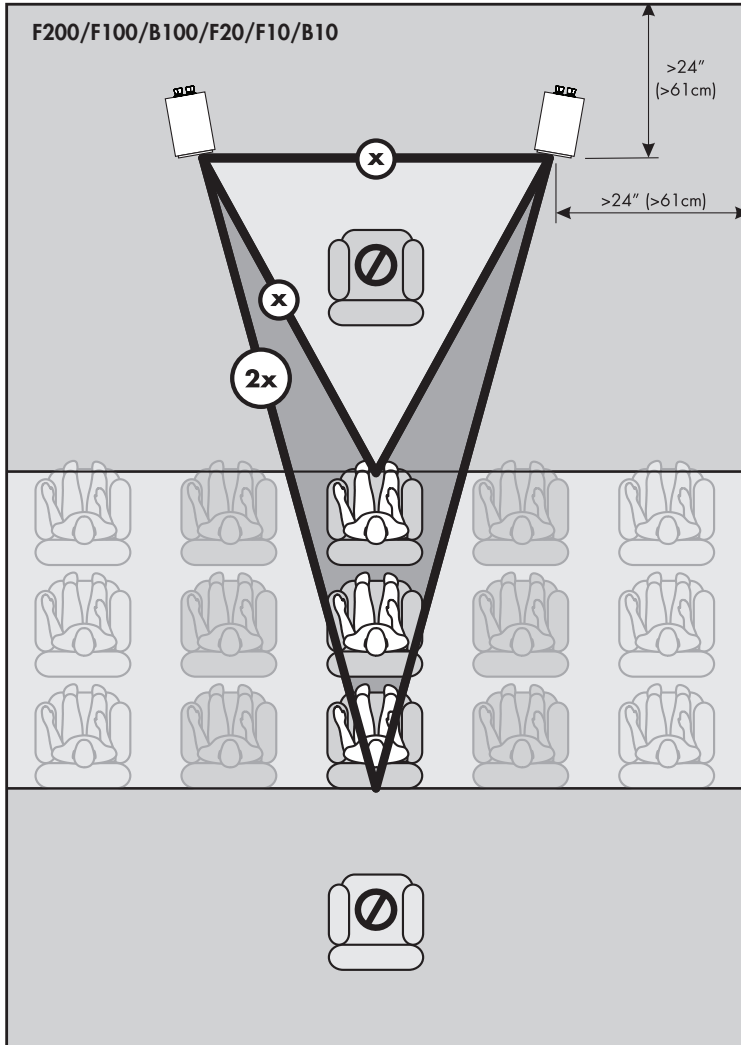



## FREQUENTLY ASKED QUESTIONS

### **How do I clean my speakers?**

Use a dust free cloth (such as a micro fiber cloth) or a soft brush to remove dust from your speakers.

**Do not spray any kind of cleaning agent on or in close proximity to the drivers.**

### **Could you suggest a list of suitable electronics and cables ideal for MartinLogan speakers?**

We have no favorites and use electronics and cables quite interchangeably. We would suggest listening to a number of brands—and above all else—trust your ears. Dealers are always the best source for information when purchasing additional audio equipment.

### **Is there likely to be any interaction between my speakers and the television in my A/V system?**

Yes. These speakers are not shielded and should be kept at least 2 feet away from a CRT television.

### **Will exposure to sunlight affect the life or performance of my speakers?**

We recommend against placing any loudspeaker in direct sunlight. Ultraviolet (UV) rays from the sun can cause deterioration of cabinet, speaker cones, etc. Small exposures to UV will not cause a problem. Filtering of UV rays through glass will greatly reduce the negative effects.

### **Should I use a 4, 6, or 8 Ohm rated amplifier with my speakers?**

All of our Motion series speakers are compatible with 4, 6 or 8 Ohm output audio amplifiers and receivers. Many of the most popular brands of AV receivers and amplifiers with 4, 6 and 8 Ohm output ratings have been thoroughly tested with all of our Motion series products and we have found no compatibility issues except under extreme listening conditions. For the best performance and sonic purity when using our Motion series products use of an amplifier or AV receiver with either a 4 or 6 Ohm output is recommended!

## TROUBLESHOOTING

### No Output

- Check that all system components are turned on and source material is playing.
  - Check speaker wires and connections.
  - Check all interconnecting cables.
  - If you are unable to resolve your problem, please contact your dealer or MartinLogan customer service (see below).
- 

## CONTACTING CUSTOMER SERVICE

### Phone

(785) 749-0133

**Monday – Friday**

8 AM – 5 PM CT

### Email

[service@martinlogan.com](mailto:service@martinlogan.com)

### Social Media



## **GENERAL INFORMATION**

### **WARRANTY INFORMATION**

Your speakers are provided with an automatic Limited 90 Day Warranty coverage. You have the option, at no additional charge, to receive a Limited 5 Year Warranty coverage. To obtain the Limited 5 Year Warranty coverage you need to complete and return the Certificate of Registration to MartinLogan within 30 days of purchase. For your convenience MartinLogan also offers online warranty registration at [www.martinlogan.com](http://www.martinlogan.com).

MartinLogan may not honor warranty service claims unless we have a completed Warranty Registration card on file! If you did not receive a Certificate of Registration with your new speakers you cannot be assured of having received new units. If this is the case, please contact your authorized MartinLogan dealer.

### **SERIAL NUMBER**

The serial number is located on back of the speaker, directly beneath the binding posts. The serial number may also be found on the product carton.

### **SERVICE**

Should you use your MartinLogan product in a country other than the one in which it was originally purchased, we ask that you note the following:

- 1 The appointed MartinLogan distributor for any given country is responsible for warranty servicing only on units distributed by or through it in that country in accordance with its applicable warranty.
- 2 Should a MartinLogan product require servicing in a country other than the one in which it was originally purchased, the end user may seek to have repairs performed by the nearest MartinLogan distributor, subject to that distributor's local servicing policies, but all cost of repairs (parts, labor, transportation) must be borne by the owner of the MartinLogan product.
- 3 If, after owning your speaker for six months, you relocate to a country other than the one in which you purchased your speaker, your warranty may be transferable. Contact MartinLogan for details.

## SPECIFICATIONS\*

### Motion XT F200

<b>Application</b> .....	Floorstanding
<b>Frequency Response</b> .....	27 Hz - 25k Hz $\pm$ 3 dB
<b>Folded Motion Waveguide Enhanced Tweeter Dispersion (VxH)</b> .....	45° x 90°
<b>Sensitivity</b> (2.83 volts/meter) .....	92 dB
<b>Impedance</b> Compatible with 4, 6, or 8 Ohm rated amplifier	4 ohms
<b>Crossover Frequency</b> .....	300Hz, 2600Hz (3-way)
<b>High Frequency Driver</b> .....	1.25" x 2.4" (3.2 x 6.1cm) Gen2 Obsidian Folded Motion XT Tweeter with 12.4 in <sup>2</sup> (79.8 cm <sup>2</sup> ) diaphragm
<b>Mid Frequency Driver</b> .....	6.5" (16.5cm) Nomex Reinforced Kevlar® cone with cast aluminum basket. Non-resonant sealed chamber format. Unibody cone construction.
<b>Low Frequency Drivers</b> .....	3x 8" (20.3cm) aluminum cones with cast aluminum baskets. Non-resonant asymmetrical chamber format. Unibody cone construction
<b>Cabinet</b> .....	Bottom Ported
<b>Recommended Amp Power</b> .....	20 - 600 watts
<b>Binding Post Inputs</b> .....	Custom bi-amp/bi-wire capable 5-way binding posts
<b>Weight</b> .....	86lbs / 39kg
<b>Dimensions (HxWxD)</b> Floorstanding model dimensions include the feet. Depth for all models include the binding posts. .	50-3/4" x 13-3/4" x 16-1/2" 128.9cm x 34.9cm x 41.9cm
<b>Finishes</b> .....	Gloss Black, Walnut, and Satin White

\*Specifications are subject to change without notice.

## Motion XT F100

Floorstanding

31 Hz - 25 kHz  $\pm$  3 dB

45° x 90°

92 dB

4 ohms

280 Hz, 2600 Hz (3-way)

1.25" x 2.4" (3.2 x 6.1cm) Gen2 Obsidian  
Folded Motion XT Tweeter with 12.4 in<sup>2</sup>  
(79.8 cm<sup>2</sup>) diaphragm

6.5" (16.5cm) Nomex Reinforced Kevlar® cone  
with cast aluminum basket. Non-resonant sealed  
chamber format. Unibody cone construction.

3x 6.5" (16.5cm) aluminum cones with cast  
aluminum baskets. Non-resonant asymmetrical  
chamber format. Unibody cone construction.

Bottom Ported

20 - 450 watts

Custom bi-amp/bi-wire capable 5-way binding posts

76lbs / 34.5kg

47-3/4" x 12-1/2" x 13-1/2" 121.3cm x  
88.6cm x 34.3cm

Gloss Black, Walnut, and Satin White

## Motion XT C100

Center Channel

42 Hz - 25 kHz  $\pm$  3 dB

45° x 90°

93 dB

5 ohms

1,300 Hz, 2,500 Hz (2.5-way)

1.25" x 2.4" (3.2 x 6.1cm) Gen2 Obsidian  
Folded Motion XT Tweeter with 12.4 in<sup>2</sup>  
(79.8 cm<sup>2</sup>) diaphragm

2x 6.5" (16.5cm) Nomex Reinforced Kevlar®  
cones with cast aluminum baskets. Non-resonant  
asymmetrical chamber format. Unibody cone  
construction. Anti-lobing 2.5-way crossover design.

—

Rear Ported

20 - 300 watts

Custom bi-amp/bi-wire capable 5-way binding posts

34lbs / 15.4kg

8" x 24" x 14-1/2" 20.3cm x 61cm x 36.8cm

Gloss Black, Walnut, and Satin White

## SPECIFICATIONS\*

## Motion XT B100

<b>Application</b> . . . . .	Bookshelf
<b>Frequency Response</b> . . . . .	45 Hz - 25 kHz $\pm$ 3 dB
<b>Folded Motion Waveguide Enhanced Tweeter Dispersion (VxH)</b> . . . . .	45° x 90°
<b>Sensitivity</b> (2.83 volts/meter) . . . . .	93 dB
<b>Impedance</b> Compatible with 4, 6, or 8 Ohm rated amplifier	4 ohms
<b>Crossover Frequency</b> . . . . .	2,600 Hz (2-way)
<b>High Frequency Driver</b> . . . . .	1.25" x 2.4" (3.2 x 6.1cm) Gen2 Obsidian Folded Motion XT Tweeter with 12.4 in <sup>2</sup> (79.8 cm <sup>2</sup> ) diaphragm
<b>Mid Frequency Driver</b> . . . . .	6.5" (16.5cm) Nomex Reinforced Kevlar® cone with cast aluminum basket. Non-resonant asymmet- rical chamber format. Unibody cone construction.
<b>Low Frequency Drivers</b> . . . . .	—
<b>Cabinet</b> . . . . .	Rear Ported
<b>Recommended Amp Power</b> . . . . .	20 - 250 watts
<b>Binding Post Inputs</b> . . . . .	Custom bi-amp/bi-wire capable 5-way binding posts
<b>Weight</b> . . . . .	20.5lbs / 9.3kg
<b>Dimensions (HxWxD)</b> Floorstanding model dimensions include the feet. Depth for all models include the binding posts. .	14-1/2" x 8" x 12-1/2" 36.8cm x 20.3cm x 31.8cm
<b>Finishes</b> . . . . .	Gloss Black, Walnut, and Satin White

\*Specifications are subject to change without notice.

## Motion F20

Floorstanding

35 Hz - 25kHz  $\pm$  3 dB

90° x 90°

92 dB

4 ohms

230 Hz, 2,600 Hz (3-way)

1" x 1.4" (2.6 x 3.6cm) Gen2 Obsidian  
Folded Motion Tweeter with 9.2 in<sup>2</sup>  
(59.4 cm<sup>2</sup>) diaphragm

5.5" (14cm) Woven Fiberglass cone with cast  
polymer basket. Non- resonant sealed chamber  
format. Unibody cone construction.

2x 6.5" (16.5cm) aluminum cones with cast  
polymer baskets. Non-resonant asymmetrical  
chamber format. Unibody cone construction.

Bottom Ported

20 - 300 watts

Custom bi-amp/bi-wire capable 5-way binding posts

60lbs / 27.2kg

44-3/4" x 11-3/4" x 14-1/4"  
112.7cm x 29.8cm x 36.2cm

Gloss Black, Walnut, and Satin White

## Motion F10

Floorstanding

38 Hz - 25 kHz  $\pm$  3 dB

90° x 90°

92 dB

4 ohms

280 Hz, 3,000 Hz (3-way)

1" x 1.4" (2.6 x 3.6cm) Gen2 Obsidian  
Folded Motion Tweeter with 9.2 in<sup>2</sup>  
(59.4 cm<sup>2</sup>) diaphragm

5.5" (14cm) Woven Fiberglass cone with cast  
polymer basket. Non- resonant sealed chamber  
format. Unibody cone construction.

2x 5.5" (14cm) aluminum cones with cast  
polymer baskets. Non-resonant asymmetrical  
chamber format. Unibody cone construction.

Bottom Ported

20 - 250 watts

Custom bi-amp/bi-wire capable 5-way binding posts

50.5lbs / 22.9kg

38-1/4" x 11-1/4" x 13-1/4" 97.1cm x  
28.6cm x 7.6cm

Gloss Black, Walnut, and Satin White

## SPECIFICATIONS\*

## Motion C10

<b>Application</b> . . . . .	Center Channel
<b>Frequency Response</b> . . . . .	63 Hz - 25 kHz $\pm$ 3 dB
<b>Folded Motion Waveguide Enhanced Tweeter Dispersion (VxH)</b> . . . . .	90° x 90°
<b>Sensitivity</b> (2.83 volts/meter) . . . . .	93 dB
<b>Impedance</b> Compatible with 4, 6, or 8 Ohm rated amplifier	4 ohms
<b>Crossover Frequency</b> . . . . .	1000 Hz, 2,000 Hz (2.5-way)
<b>High Frequency Driver</b> . . . . .	1" x 1.4" (2.6 x 3.6cm) Gen2 Obsidian Folded Motion Tweeter with 9.2 in <sup>2</sup> (59.4 cm <sup>2</sup> ) diaphragm
<b>Mid Frequency Driver</b> . . . . .	2x 5.5" (14cm) Woven Fiberglass cones with cast polymer baskets. Non- resonant sealed chamber format. Unibody cone construction. Anti-lobing 2.5-way crossover design.
<b>Low Frequency Drivers</b> . . . . .	—
<b>Cabinet</b> . . . . .	Rear Ported
<b>Recommended Amp Power</b> . . . . .	20 - 200 watts
<b>Binding Post Inputs</b> . . . . .	Custom 5-way binding posts
<b>Weight</b> . . . . .	23.5lbs / 10.7kg
<b>Dimensions (HxWxD)</b> Floorstanding model dimensions include the feet. Depth for all models include the binding posts. .	7-1/4" x 19" x 11-1/2" 18.4cm x 48.3cm x 29.3cm
<b>Finishes</b> . . . . .	Gloss Black, Walnut, and Satin White

\*Specifications are subject to change without notice.



## Motion B10

Bookshelf

56 Hz - 25 kHz  $\pm$  3 dB

90° x 90°

92 dB

5 ohms

2,370 Hz (2-way)

1" x 1.4" (2.6 x 3.6cm) Gen2 Obsidian  
Folded Motion Tweeter with 9.2 in<sup>2</sup>  
(59.4 cm<sup>2</sup>) diaphragm

5.5" (14cm) Woven Fiberglass cone with cast  
polymer basket. Unibody cone construction.

—

Rear Ported

20 - 200 watts

Custom 5-way binding posts

14.5lbs / 6.6kg

12-1/2" x 7" x 9-3/4"  
31.8cm x 17.8cm x 24.8cm

Gloss Black, Walnut, and Satin White

## Motion MP10

Multi-Purpose

81 Hz - 25kHz  $\pm$  3 dB

90° x 90°

9

2 dB

5 ohms

2,100 Hz (2-way)

1" x 1.4" (2.6 x 3.6cm) Gen2 Obsidian  
Folded Motion Tweeter with 9.2 in<sup>2</sup>  
(59.4 cm<sup>2</sup>) diaphragm

5.5" (14cm) Woven Fiberglass cone with cast  
polymer basket. Unibody cone construction.

—

Stealth Rear Ported

20 - 200 watts

Custom 5-way binding posts

9.7lbs / 4.4kg

14" x 8" x 5"  
35.6cm x 20.3cm x 12.7cm

Gloss Black, Walnut, and Satin White

# F200

MOTION XT®  
by MARTIN LOGAN®

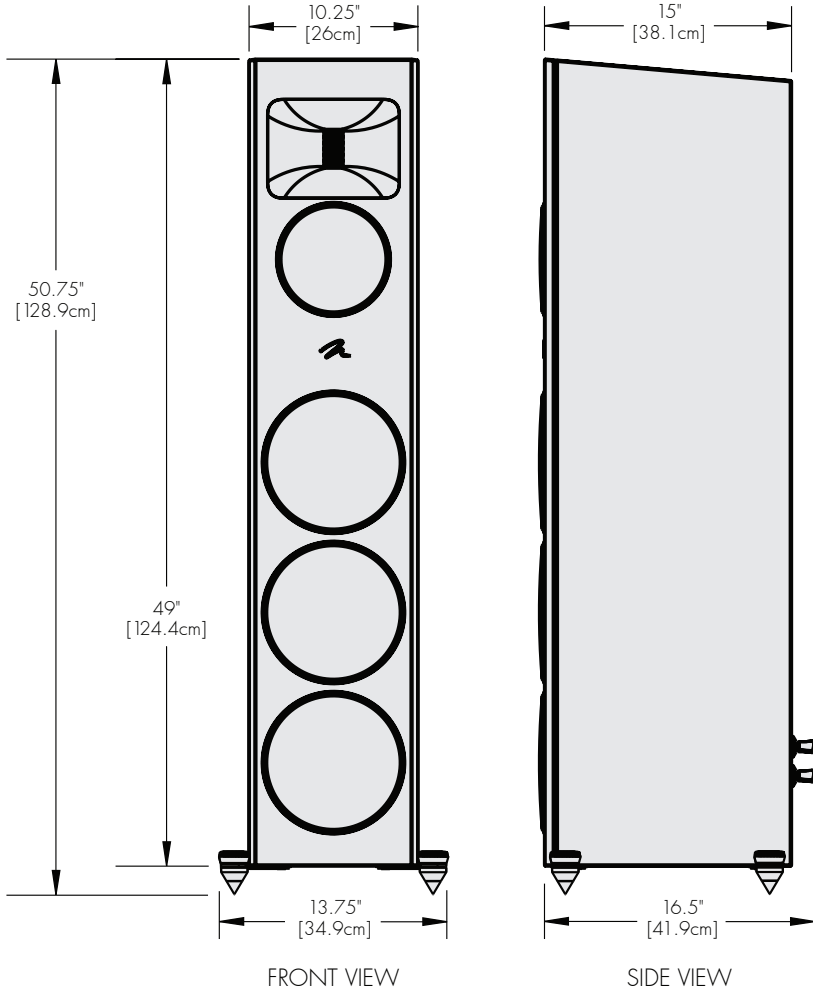

# F100

MOTION XT®  
by MARTIN LOGAN®

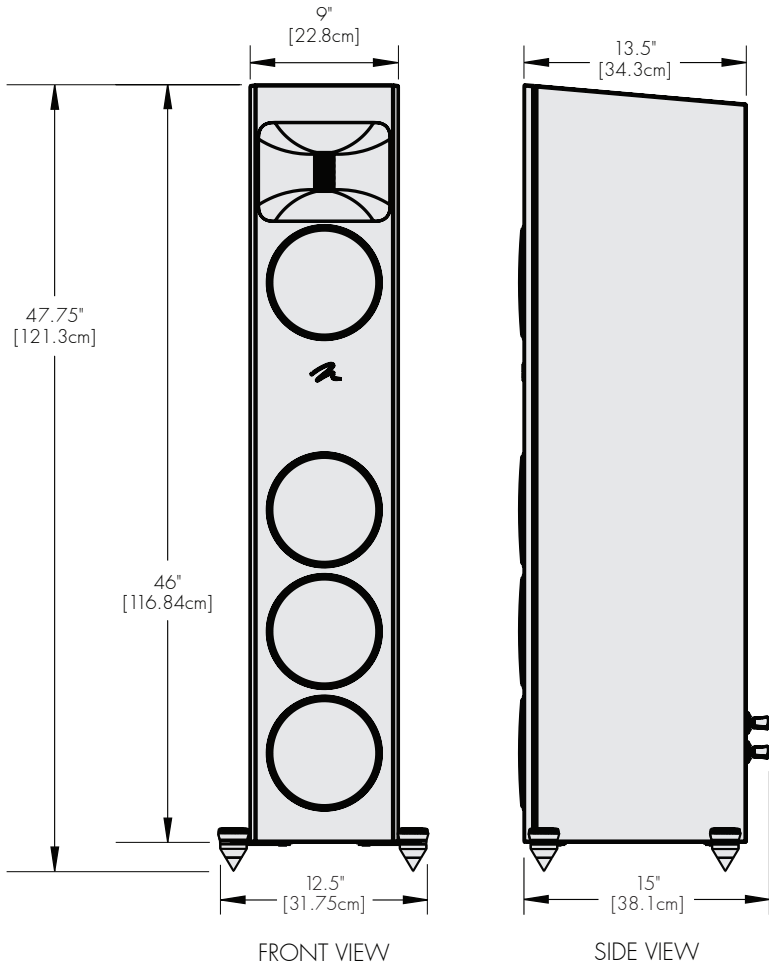

# C100

MOTION XT®  
by MARTIN LOGAN®

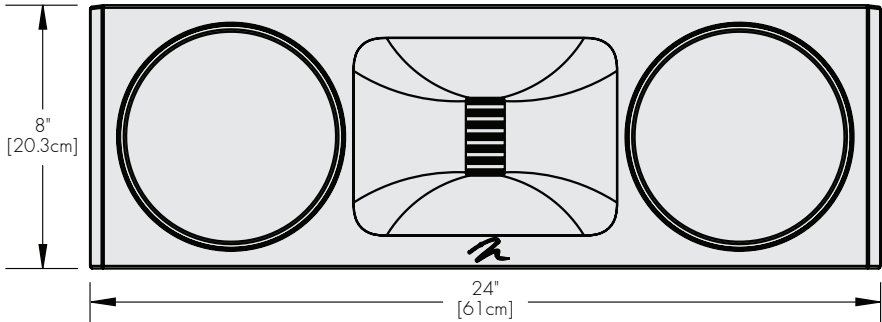

FRONT VIEW

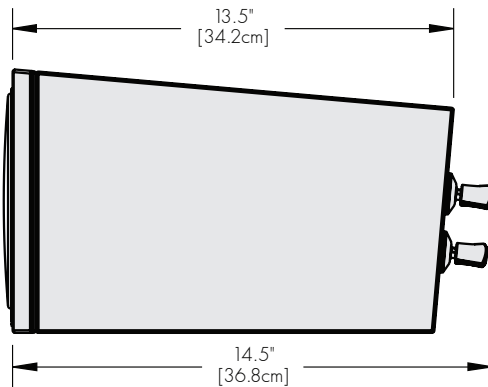

SIDE VIEW

# B100

MOTION XT®  
by MARTIN LOGAN®

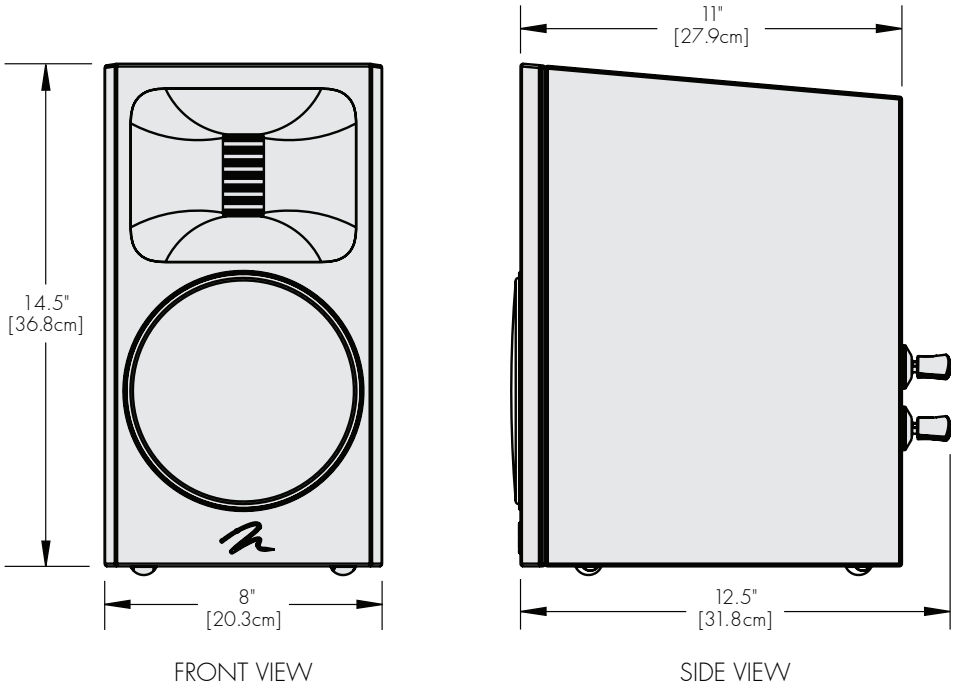

# F20

MOTION®  
by MARTIN LOGAN®

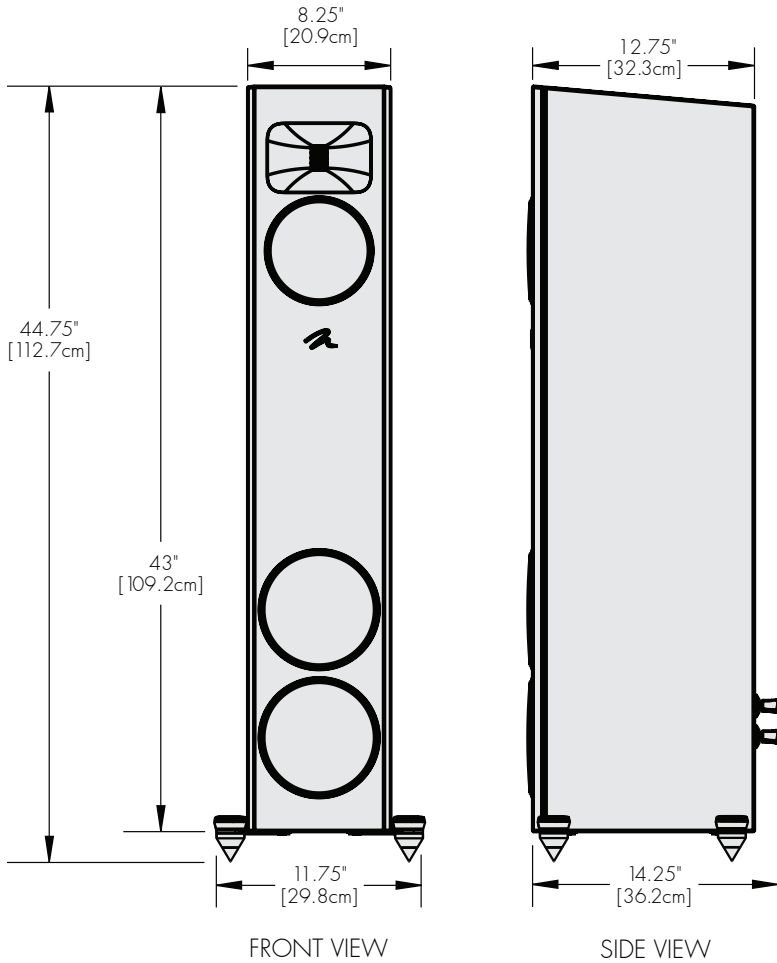

# F10

MOTION®  
by MARTIN LOGAN®

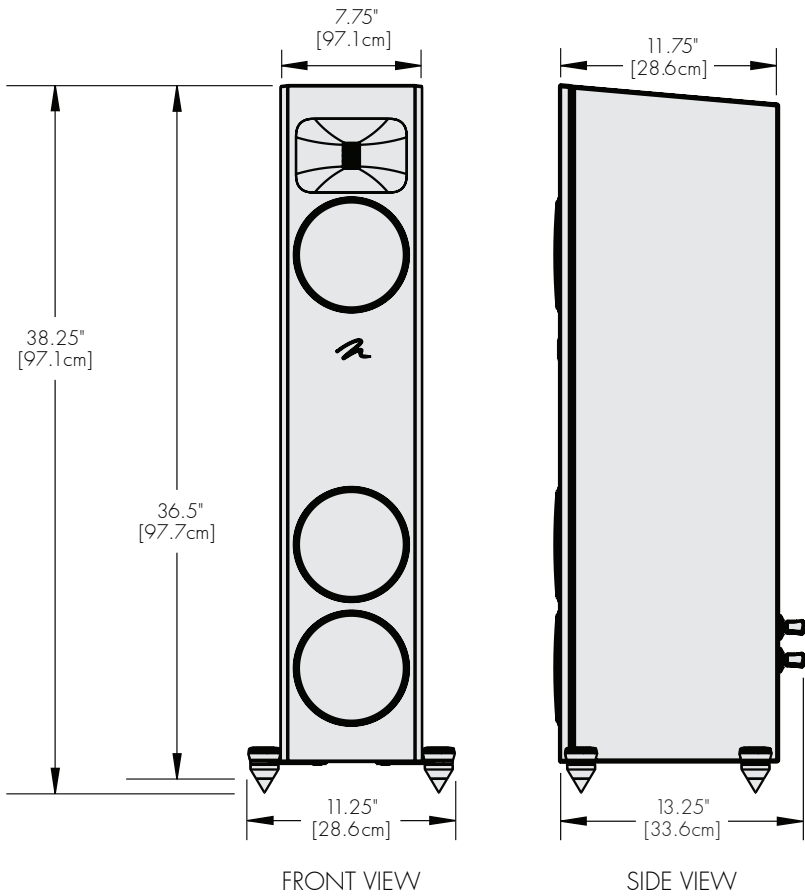

# C10

MOTION®  
by MARTIN LOGAN®

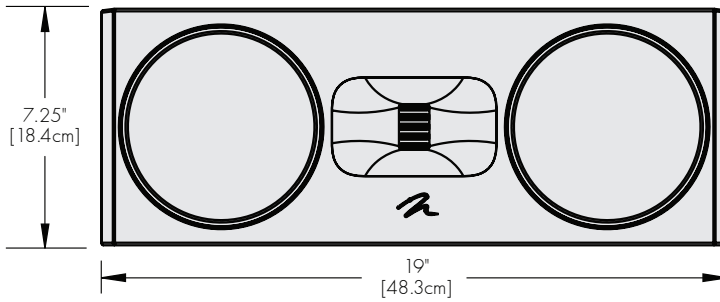

FRONT VIEW

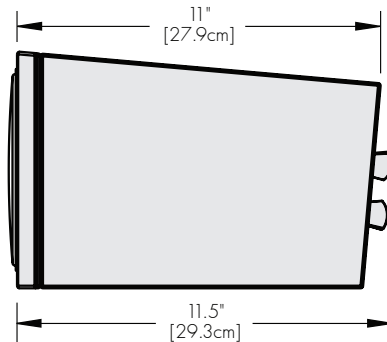

SIDE VIEW



# B10

MOTION®  
by MARTIN LOGAN®

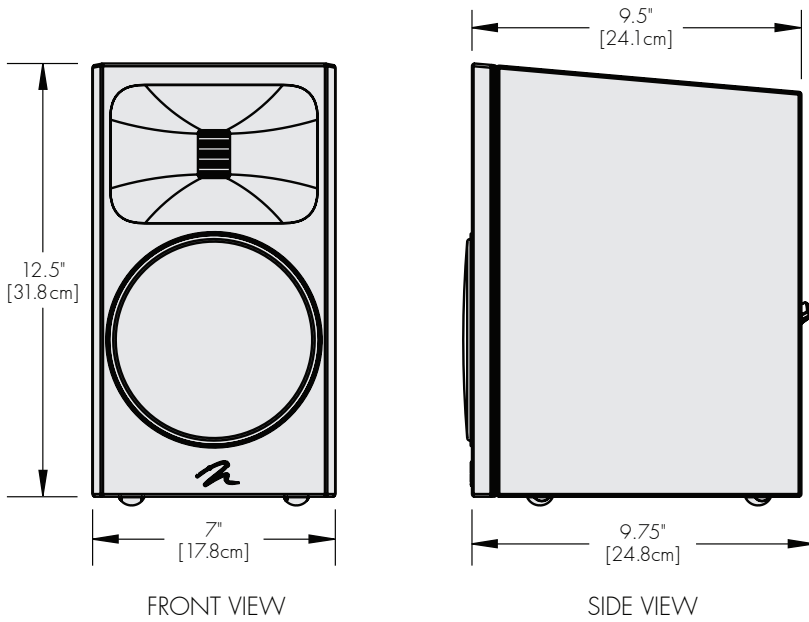

# MP10

MOTION®  
by MARTIN LOGAN®

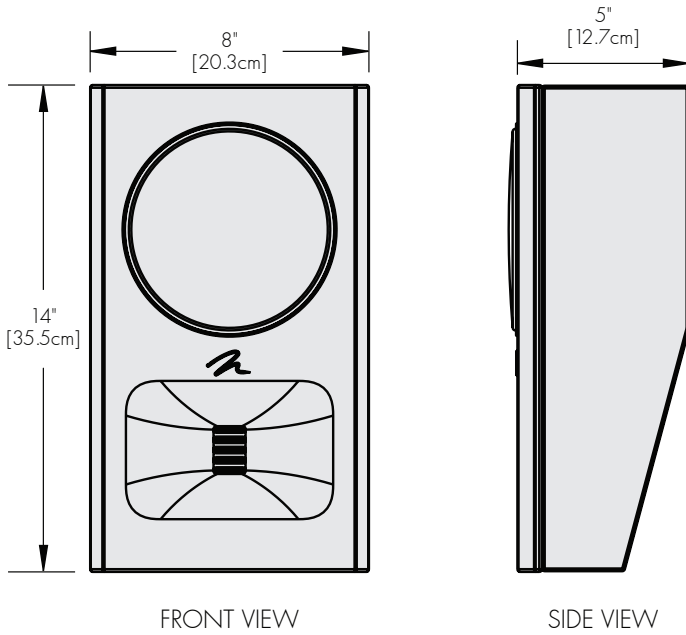





**MARTIN LOGAN®**

Lawrence, Kansas, USA   tel. 785.749.0133   fax 785.749.5320   [www.martinlogan.com](http://www.martinlogan.com)

©2023 MartinLogan Ltd. All rights reserved.

Rev. #001